

MOOVE-X



The innovative **patented system** to position heavy materials by **wireless**

The MOOVE-X systems was designed starting from the over thirty years of experience in high precision machining of OMPE Srl . The system is composed by a wireless dedicated hotspot (the MOOVE.TOTEM) on which there is a software (MOOVE.SW) and from one to eight wireless levellers (MOOVE-L). It is possible to connect to the system using any device and move the levellers (singularly or in sync mode) to lift heavy materials with a maximum of 10 tons for each leveller with a repeatability of 0.01 mm .

SEMPPLICITY



Plug & play

It is not necessary to configure the system. You have just to plug the MOOVE.TOTEM in a socket, turn on the MOOVE-L and it is ready to use.



Wireless

It works without cables.



Intelligent charge

It is provided with last generation of LiPo batteries, magnetic connector for recharge and power recharger at seven optimized phases. The recharge activity is simple, fast and MOOVE-L will not use the battery if turned off.



Strong and durable

It is designed to be durable and strong. It is IP66, resistant to shavings and usable in hostile situations.



SMART

Scalable

Whenever desired, it is possible to add new MOOVE-L in addition to those initially provided



Precise

It allows to move heavy material with a repeatability of 0.01mm and a resolution of 1µ.



Portable

It could be moved depending on needs and without installation activities.



Safe

It is based on authentication systems and safety control hold-to-run button.



Intuitive

It is possible to access to the software using any internet browser. It is compatible with all the operative systems (both desktop and mobile) and you can use your preferred device.

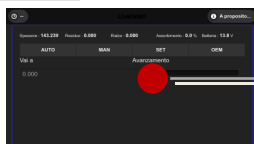
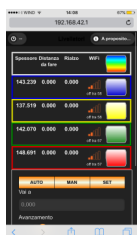

76% increased efficiency in positioning activities

The system revolutionizes the positioning methods and reduces the times dedicated to position materials.

240 saved hours per year for downtimes per turn

Thanks to efficiency it is possible to increase the mean production of machines.

Better quality in positioning of raw materials

The system allows to increase quality and accuracy of positioning activities.

Reached results in 24 months of experience in using the MOOVE-X

The impact of MOOVE-X on positioning activities related to mechanical machining is difficult to be assessed. It depends on different drivers such as: complexity and length of positioning, geometrical deformation of the single part, total time of machining and total cost of the working machine. Before be available on the market, the system was used on machines in effective production. Relating to the time of positioning recorded using traditional position systems, the MOOVE-X reduced the time for positioning between 69% and 79% in the case of traditional positioning of 2 hours and 30 minutes and between 43% and 27% in the case of traditional positioning of 30 minutes. In addition, depending on the time of positioning and the length of machining activities, it showed a reduction in total hours for positioning activities around 240 hours per turn.

Increase in efficiency using MOOVE-X*

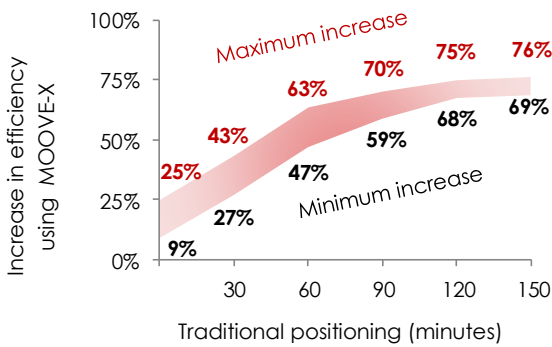

Annual reduction in hours dedicated to positioning per turn using MOOVE-X**

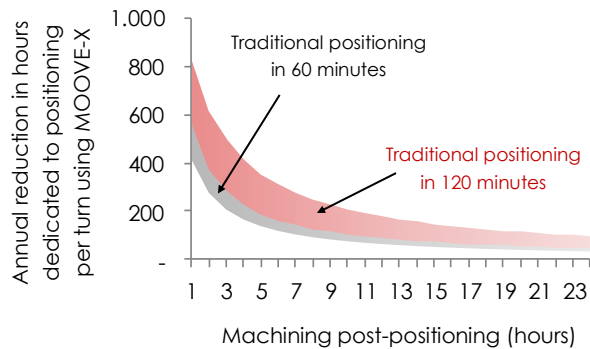

* Computation is based on statistical data collected by OMPE from 01/01/2014 and 31/12/2015. ** The calculation is base on a turn of 8 hours and 220 working days.

System specifics

MOOVE-L (Leveller)

Dimensions (LxPxH)	325 mm x 367 mm x 134,2 mm
Weight	33,0 kg
Wi-Fi protocol	802.11n
Signal range	100 m in open field
Power source	12 v
Time to charge	120 min
Velocity of movement	3,5 mm/min
Maximum run	16 mm
Resolution	1 μ
Maximum loading	10.000 kg
Temperature of operation	From -15° C to +50° C
Permeability	IP66
Available colours	<ul style="list-style-type: none"> ● Blue ● Yellow ● Purple ○ White ● Red ● Green ● Black ● Azure

MOOVE.SW (software)

Interface	HTML5
Supported O.S.	All
Device requirements	Browser Wireless connection

MOOVE-TOTEM (wireless hotspot)

Dimensions (LxPxH)	95,3 mm x 77,3 mm x 30,0 mm
Weight	0,3 kg
Wi-Fi protocol	802.11n
Signal range	100 m in open field
Power source	5 v

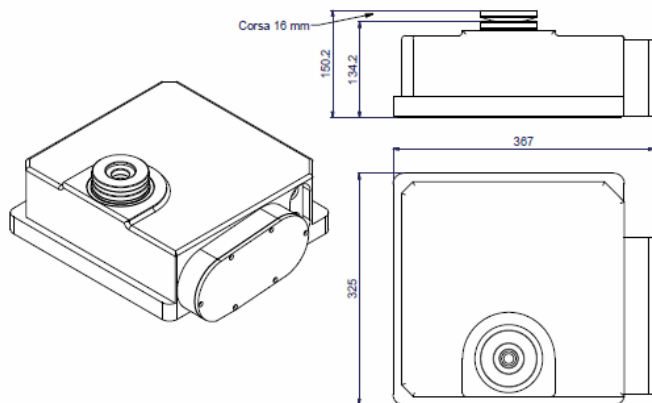

The system MOOVE-X is patented, produced and sold by:



OMPE Srl
Via Camozzi, 20 - 24060 - San Paolo d'Argon (BG)
Tel. +39 035 958361 fax: +39 035 958848D

